



THE M-SERIES



500-1250 TON



THE M-SERIES

500-1250

Introducing the next Generation in Milacron's cutting edge two-platen Technology. Milacron expands on its industry leading mid tonnage product line through the introduction of the M-Series, powered by an energy efficient FANUC servo-motor hydraulic system, the gold standard in rugged reliability.

The all-new M-Series product line is designed to exceed the demands of global automotive, houseware/appliances, construction, and similar molded parts with its higher max mold weights, faster clamp speeds, and a compact clamp footprint.

2



PROVIDING THE MOST VERSATILE POWER HOUSE IN **RELIABILITY, PERFORMANCE AND SPECIFICATIONS**



- Ⓜ Rugged clamp design
- Ⓜ Compact clamp footprint
- Ⓜ Improved mold and eject access
- Ⓜ 3-configurable pump packages for customized application solutions
- Ⓜ Precise mold guidance with LM guides on the moving platen
- Ⓜ Full SPI pattern on moving and stationary platens.
- Ⓜ Mosaic+ control
- Ⓜ Environmentally friendly
 - Reduced footprint
 - Reduced dry cycle time
 - Reduced lubrication
- Ⓜ FANUC motors and drives



M-SERIES

COMPACT 2 PLATEN TECHNOLOGY

- Minimal platen deflection
- Chrome plated strain rods
- Decreased nut lock operating time
- Grease-free mold area

NEXT GENERATION TONNAGE ASSEMBLY

- Increased seal life due to fully supported strain rods in the stationary platen
- Chrome plated strain rods
- Equal distribution of tonnage load on the threads, due to the conical design tonnage piston
- Synchronized tonnage & pancake cylinder
- Precise and short tonnage build up time
- Higher break away force available as standard

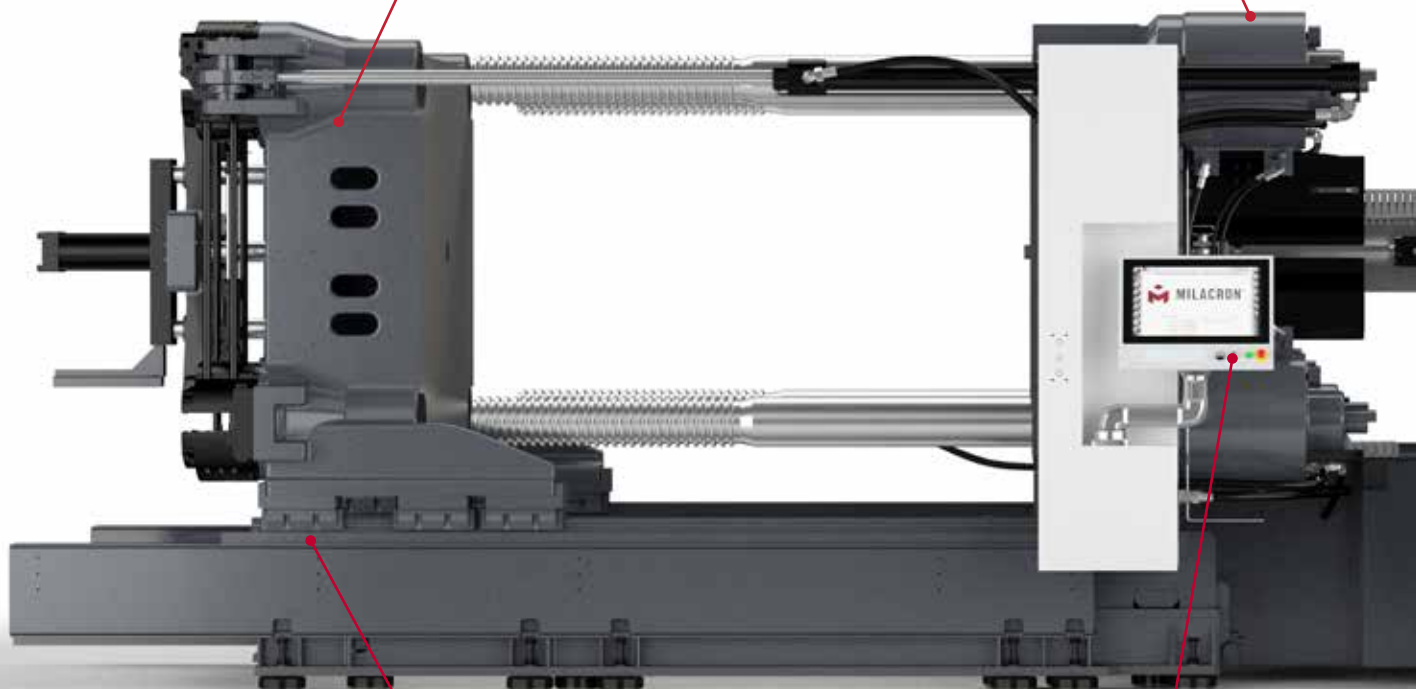

4

CLAMP ON LM GUIDES

- Frictionless movement
- Enhanced platen parallelism & squareness – increase mold life
- Contactless strain rods

MOSAIC +

- 21-inch multi-touch screen with configurable “PLUS” area
- Integrated auxiliary equipment screens
- Integrated remote camera interface provides an additional set of eyes monitoring the entire machine (optional)

INTEGRATED 5 AXIS SERVO ROBOT (OPTIONAL)

- Ultimate in mounting flexibility
- Integrated robot control through machine HMI



MULTIPLE STANDARD INJECTION FRAMES

- A'-A-B barrel combination for application flexibility
- Twin cylinder injection unit distributes the force evenly across the screw centerline
- Precision linear guides for accurate screw and barrel alignment
- Standard injection unit swivel for ease of maintenance

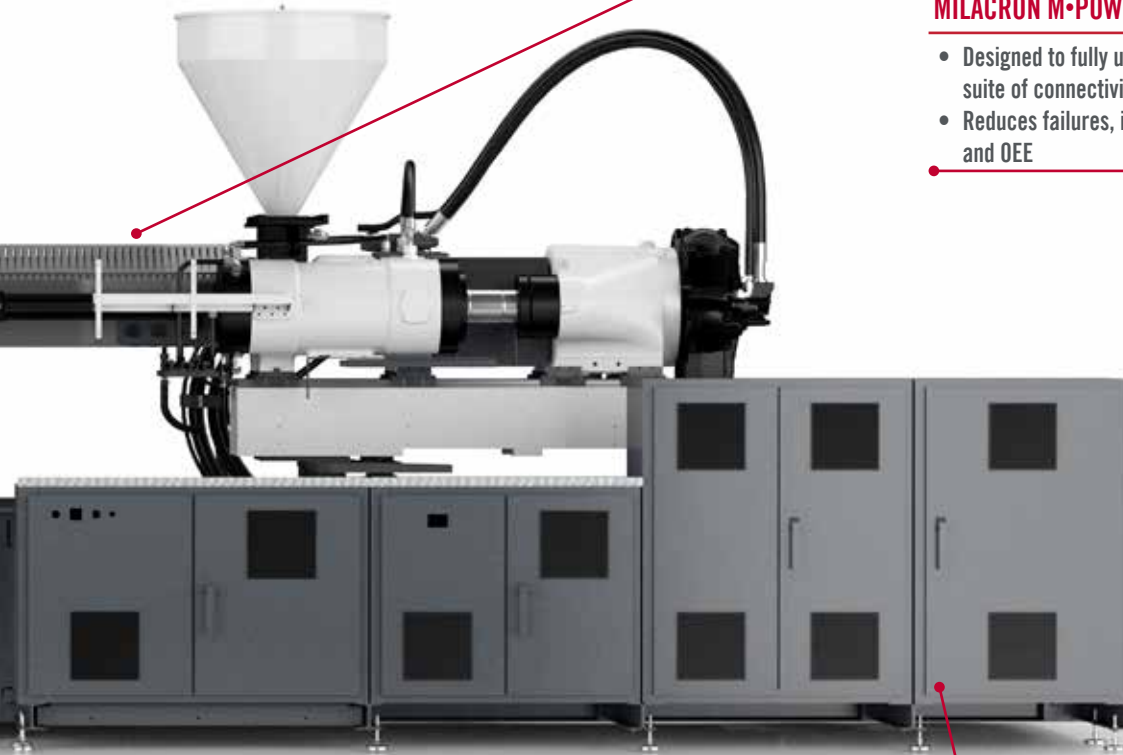

MILACRON M-POWERED

- Designed to fully utilize our M-powered suite of connectivity products
- Reduces failures, improves uptime and OEE

INTEGRATED HOT RUNNER CONTROLLER (OPTIONAL)

- Mold-Masters TempMaster iM2 controller
- Seamless Integration
- Reduced mold interface complexity
- Virtual Network Control (VNC) controlled via Mosaic control screen
- Widest selection of interchangeable control cards

HIGHLY RELIABLE SERVO DRIVEN PERFORMANCE

- Compact size servo motor
- High dynamics
- Low inertia
- Higher power density - high torque with lower current
- EMI filters included for better noise suppression & life of other electronic components
- Suitable for all applications

**SMALLER.
FASTER.
BETTER.**

M-SERIES

Realize the benefits of configuring a machine that is perfectly suited to your production requirements. The M-Series has expanded options available and can be configured for a large range of parts and applications by combining the clamp and injection unit with screw and barrel combinations.

INJECTION UNIT SPECIFICATIONS

Frame	2290	3470	4880	6610	10100	13500	16000	23000
M-SERIES 500								
M-SERIES 600								
M-SERIES 725								
M-SERIES 900								
M-SERIES 1070								
M-SERIES 1250								

CLAMP SPECIFICATIONS

MODEL	TONNAGE		MOLD WEIGHT CARRYING CAPACITY		TIE BAR SPACING		MAX DAYLIGHT		MIN / MAX MOLD	
	kN	US tons	kg	lbs	mm	inch	mm	inch	mm	inch
M-SERIES 500	4500	506	7000	15400	920 x 920	36.2 x 36.2	1850	72.8	400 / 900	15.7 / 35.4
M-SERIES 600	5500	618	9500	20900	1100 x 920	43.3 x 36.2	2000	79	400 / 1000	15.7 / 39.4
M-SERIES 725	6500	731	12000	26500	1150 x 1000	45.3 x 39.4	2050	81	450 / 1100	17.7 / 43.3
M-SERIES 900	8000	899	17000	37500	1350 x 1100	53.1 x 43.3	2300	90.5	500 / 1200	19.7 / 47.2
M-SERIES 1070	9500	1068	19500	43000	1500 x 1120	59.1 x 44.1	2500	98.4	600 / 1300	23.6 / 51.2
M-SERIES 1250	11000	1236	23500	51800	1550 x 1200	61.0 x 47.2	2600	102.4	600 / 1400	23.6 / 55.1

APPLICATIONS

The M-Series is designed to meet the changing demands of a global market, with oversized clamp specs, greaseless part drop, and precision linear ways.

- *AUTOMOTIVE*
- *HOME APPLIANCES*
- *MATERIAL HANDLING*
- *STORAGE & TRANSPORT CONTAINERS*
- *PACKAGING*
- *CONSTRUCTION*



CLAMPING UNIT

The all new global M-Series true two platen injection molding machine.

- Ⓜ Mechanically synchronized nut lock design
- Ⓜ Industry leading tie bar spacing to accommodate a wide variety of molds
- Ⓜ Easy access through clamp end-door to access knock out bar
- Ⓜ Power operated gate for faster mold changes and part take out
- Ⓜ Full SPI pattern on platens and knockout bars. T-Slot platens available
- Ⓜ Patent applied Flex plate technology for out-of-square molding and reduced mold wear



CORNER TONNAGE

Ⓜ Built on the stationary platen for a faster dry cycle time to increase productivity.

ROBUST NUT LOCK DESIGN

Ⓜ Synchronized top and bottom nut locks working in parallel are mechanically linked to improve the reliability and repeatability over the life of the machine.

PRECISION LINEAR GUIDES

Ⓜ Extended moving platen support runs on linear guides with grease free mold area, reduced friction, improved clamp parallelism, reduced mold wear and greaseless part drop area. More aggressive ramping at mold close and mold open to improve dry cycle times.

KIDNEY LOOP FILTRATION SYSTEM

Ⓜ Independent kidney loop filtration system allows filtration to run continuously, if preferred, via the control and maintains a three micron filtration.



Tonnage Cylinder



Traverse Cylinders with Trunnion Mount



Large Integrated Support Shoes

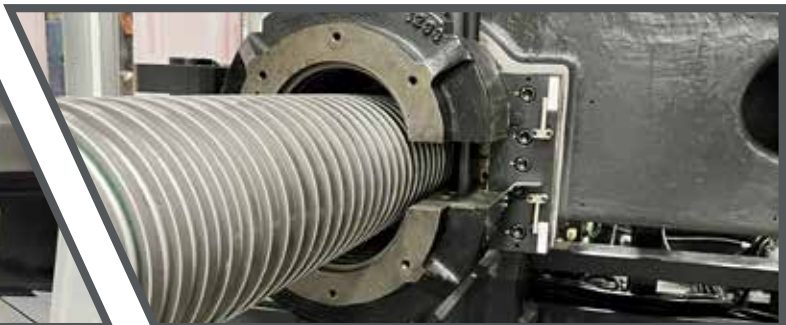

Robust Nut Lock Assembly

INJECTION UNIT

Milacron offers a wide selection of injection unit sizes, barrels and screws for the M-Series product line, increasing customer flexibility in processing.

- ④ Precise linear guide ways reduce misalignments and mechanical frictions
- ④ Injection unit swivel for easy screw removal
- ④ Hydraulic power swivel on 10100 injection frames and above
- ④ Higher L/D ratio – better plasticizing and homogeneity
- ④ Industry proven pull-pin clevis design for easy injection unit swivel
- ④ Twin cylinder injection unit for equally distributed load across the screw centerline
- ④ 10-stage injection velocity and 15-stage injection pressure profiles



10



Purge area

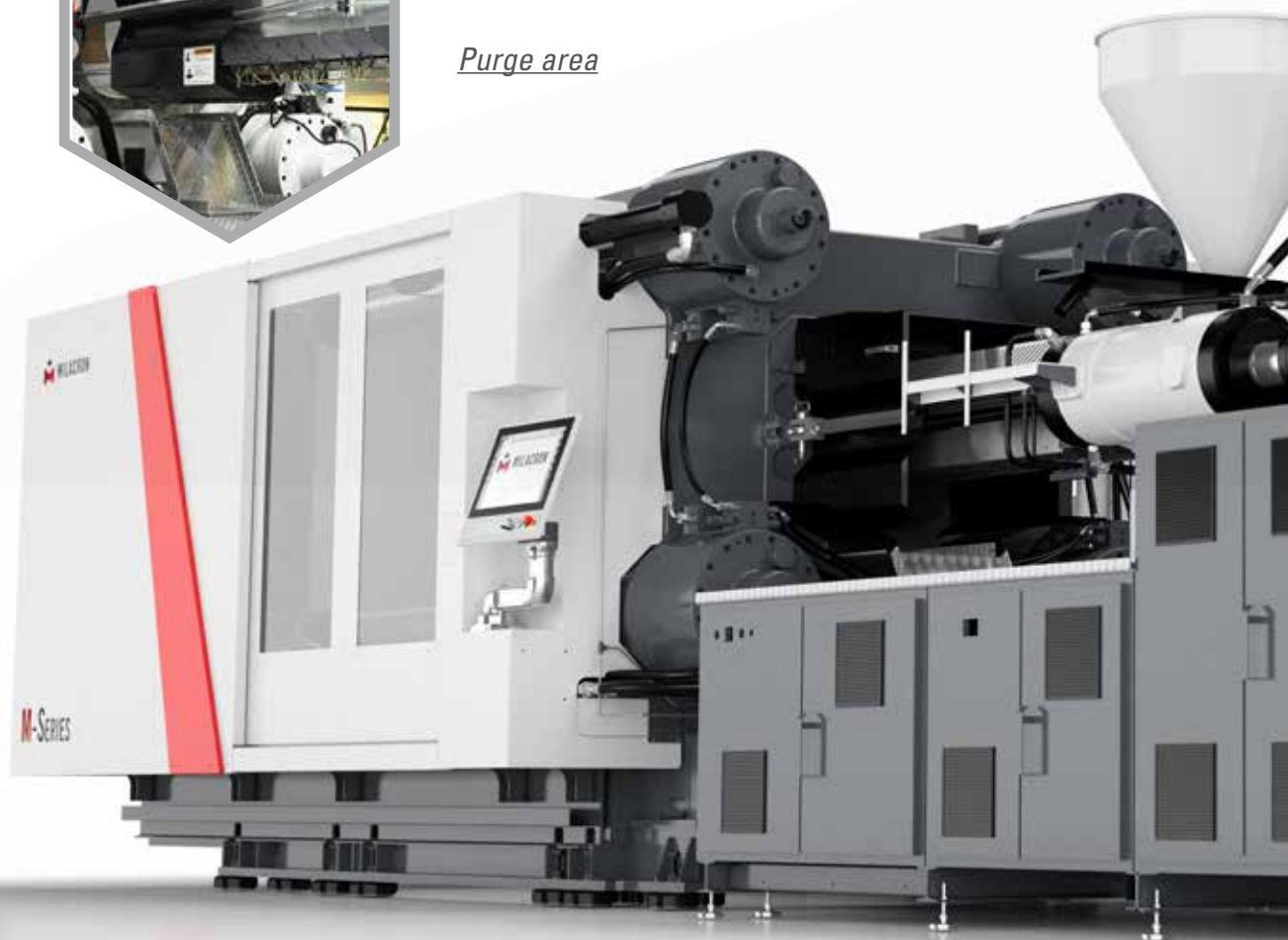

- Ⓜ 10-stage screw speed and 10-stage back pressure control through screen
- Ⓜ Digital setting of extruder RPM and digital read out of actual RPM
- Ⓜ Switch over from fill to pack based on position, time and pressure
- Ⓜ Analog position transducer for accurate injection position control
- Ⓜ Open access to purge area
- Ⓜ Three freely configurable pump packages for increased injection specifications



Extruder motor



*Linear ways
for injection*

ONE MILACRON, INFINITE POSSIBILITIES

SERVO- HYDRAULIC SYSTEM

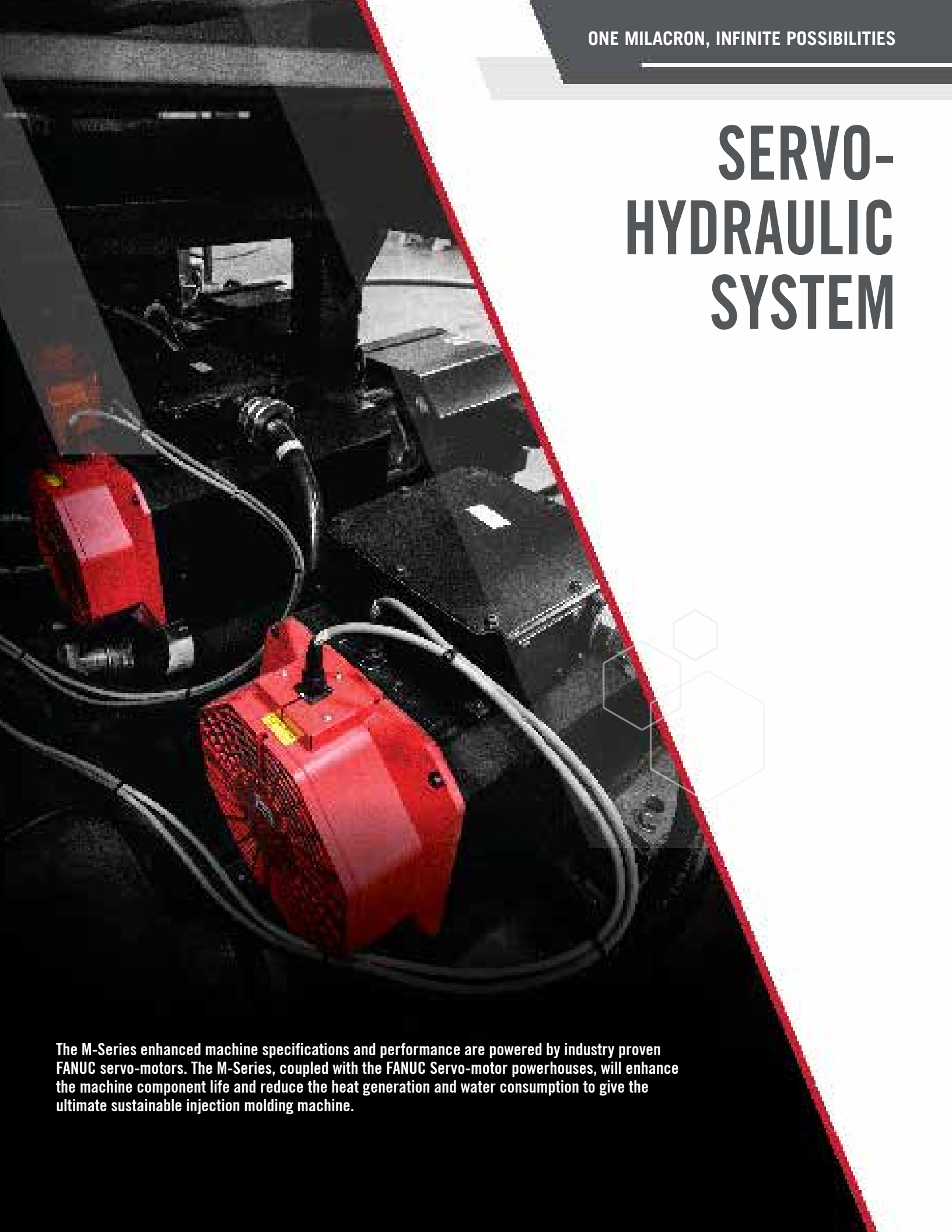

The M-Series enhanced machine specifications and performance are powered by industry proven FANUC servo-motors. The M-Series, coupled with the FANUC Servo-motor powerhouses, will enhance the machine component life and reduce the heat generation and water consumption to give the ultimate sustainable injection molding machine.

BENEFITS INCLUDE

- Ⓜ Improved cycle precision and repeatability – closed loop system
- Ⓜ Reduced energy consumption
- Ⓜ Increased accuracy and precision – rotational control to a fraction of a degree
- Ⓜ High response – low inertia
- Ⓜ Noise reduction – up to 80% quieter than conventional hydraulic machines
- Ⓜ Ability to remotely monitor for troubleshooting and analysis
- Ⓜ Reduced sensitivity to contamination
- Ⓜ Increased reliability and lower maintenance costs
- Ⓜ Bi-directional pump for fast response in pressure control
- Ⓜ Pump is stopped intermittently during the cycle
- Ⓜ Servo-system designed for demanding and diverse applications

FANUC HIGH-PERFORMANCE, HIGH-EFFICIENCY SERVO-MOTORS

- Ⓜ 50 years mean time between failures (MTBF)
- Ⓜ High-efficiency servo-system uses power generated during deceleration of motors, excellent energy-saving performance
- Ⓜ Designed to meet global safety standards (ANSI and CE)
- Ⓜ FANUC motors use high-energy neodymium magnets, for superior cost and performance ratios



MOSAIC+ CONTROLLER SYSTEM

It's easy to maximize the reliability and adaptability of Milacron machines with the ergonomic touch-screen control of MOSAIC+. Fast processing speeds power extensive data collection and report generation, as well as integration with automation controls to further simplify the whole process.

EXCEPTIONAL STANDARD FEATURES

- Multi-touch capable 21.5" HD touch screen
- Intuitive operator interface
- Configurable screen layout
- Remote mounted IP camera interface
- Windows-based operating system
- Optional integrated Mold-Master hot runner control



MOSAIC+ screen versatility gives the operator simultaneous views of multiple machine functions and related equipment, such as hot runner control and remote-mounted IP cameras.

- Set point overview page for quick access – actual set points for each axis at the bottom of the page
- Display of 700 process monitor samples stored on control or virtually unlimited samples on USB stick or network drive via reports
- Graphic display of 33 integrated soft keys with LED's located below screen
- Process monitoring of over 50 possible parameters with graphically displayed min, max, and average
- 8 + 8 freely configurable I/O
- Self-diagnostic and fault-finding capability
- 8 SPC distribution, XBar, and R charts with over 50 possible parameters
- Data protection with 4 access levels for up to 30 machine operators
- Fully-configurable cores
- Save mold data and screen shots to USB keys
- Change log and alarm log are 700 on the control, virtually unlimited on USB stick or network drive via reports

PLUS SCREEN TECHNOLOGY

The PLUS section has four configurable window spaces. In this section, the operator can choose to show:

- 🔴 Four small windows
- 🔴 One large and two small windows
- 🔴 Two large windows

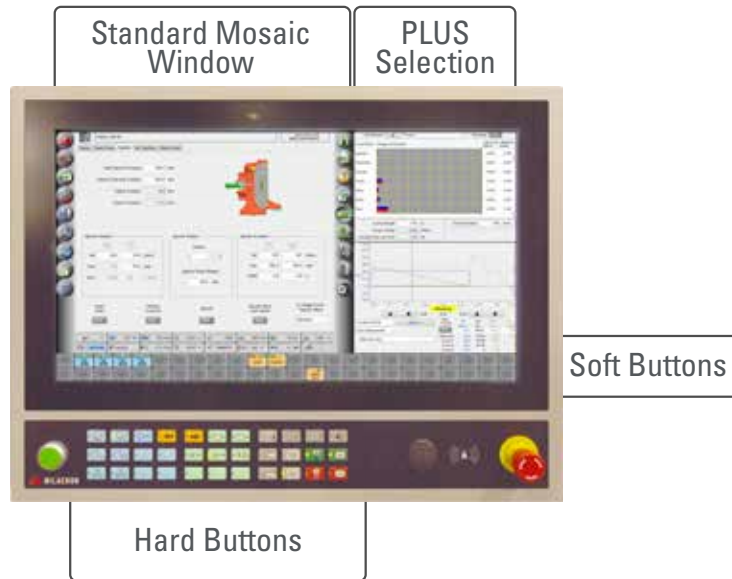

Content choices for the four windows include:

- 🔴 Alarms log
- 🔴 Energy overview
- 🔴 Production run
- 🔴 Injection graphics
- 🔴 Trend data analysis
- 🔴 Trend graphics
- 🔴 Cycle analysis
- 🔴 SPC charts
- 🔴 Integrated robot, dryer and hot runner (optional)
- 🔴 Status page
- 🔴 Integrated camera with zoom capability (optional)

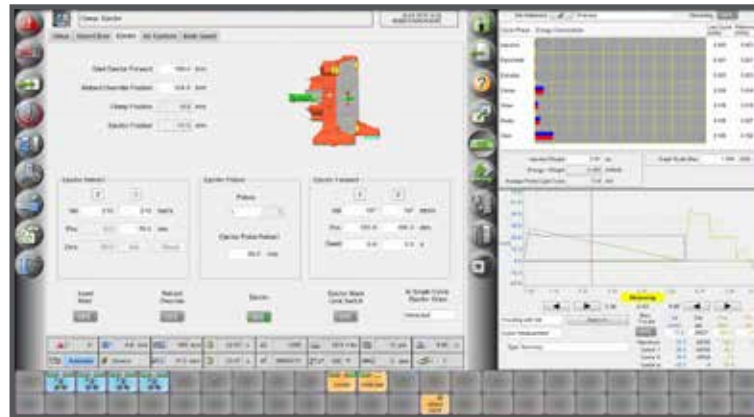

HIGH-QUALITY COMPONENTS



1. Servo motors / Drives – FANUC

2. High Speed traverse Cylinders – Douce Hydro / Atos



3. Control hardware – B&R

4. Control valves – Rexroth



5. Fixed gear pump – Eckerle

6. Filtration - Hydac



7. Linear ways – THK

8. Extruder motor – Calzoni

STANDARD FEATURES

GENERAL	Standard	Optional
Advanced 2 Platen Technology powered by energy efficient servo motor hydraulic system	●	
Direct control of pressure and flow via internal gear pumps	●	
Multiple servo motor system for optimum efficiency and independent operations of eject and core pull	●	
Improved layout of manifolds and hoses on non-operator side	●	
Monitored shut off valve to pump suction lines	●	
Designed for serviceability (test ports, access, etc.)	●	
Independent full time kidney-loop filtration and cooling 3 Micron (Optional external filtration system)	●	
Filtration to 3 micron with clog detection and alarm	●	
Ports for external auxiliary filtration plumbing	●	
High base designs for part removal		○
Robot Interface ANSI146 (compatible with Euro-map 67)	●	
SPI Robot mounting pattern on stationary platen	●	
Electric Power operated operator's gate (M600 - 1250 ton) machines.	●	
Ejector area safety interlocked access door	●	
Flareless bite type fittings with elastomeric seals for hydraulic tubes connections	●	
Improved mold area access (Optional mold area platform)	●	○
Ventilated control cabinet mounted outside of base with over temperature alarm	●	
Leveling pads	●	
Y strainer in heat exchanger inlet for all machines	●	
Separate IN/OUT connection for cooling water requirements of heat exchanger and feed throat	●	
UPS for Controller	●	
Non operator side cycle interrupt buttons	●	

EJECT	Standard	Optional
Standard machine mounted eject system (SPI)	●	
Pulsating ejection	●	
Position transducer used for setup and readout of ejector positions	●	
Proportional control of eject speed and pressure (operator adjustable at control)	●	
Two forward eject speed set points	●	
Eject forward dwell timer	●	
Eject retract override	●	
Intermediate eject retract set point	●	
Eject on fly/independent eject	●	
Eject retract limit switch verification (software/signals only)		○

CLAMP	Standard	Optional
2 Platen Clamp design with tonnage pads on Stationary	●	
Synchronized Integrated Nut Lock System	●	
Compact footprint	●	
Increased max mold weight capacity	●	
Reduced (Euro-map 6) dry cycle times	●	
Position based ramping of the Moving Platen	●	
SPI mold mounting pattern on platens	●	
Extended moving platen support shoes riding on LM guideways	●	
Replaceable die locating ring on stationary platen	●	
Pre-clamp open sequence	●	
Generously tapered conical hole in stationary platen	●	
Traverse cylinders for fast traversing speeds and mold break-away force	●	
Increased breakaway force using main cylinder area	●	
Chrome plated strain rods	●	

INJECTION	Standard	Optional
Twin cylinder injection units for compact footprint	●	
Parallel mounted twin pull-in cylinders for even nozzle force distribution	●	
Closed loop injection pressure and velocity control (Thru Pump)	●	
ON/OFF valve feed throat temperature alarm	●	
Injection fill to pack by screw position, volume, pressure, or time	●	
Direct drive single stage hydraulic screw motor	●	
Ball Check or short stroke slider ring		○
Nozzle contact force by pressure switch Transducer	●	
Spruebreak by timer	●	
Solid State relays for barrel heats	●	
Injection unit swivel for easy nozzle, screw, and barrel maintenance (power swivel 10100 and larger)	●	
J-Style Thermocouples	●	
Hopper slide with shutoff, open/close, op side emptying Optional powered slide	●	○
Ceramic Insulated heater bands	●	
Heater zones labeled per Euro map 5	●	

MACHINE POWER PACK	Standard	Optional
3 Performance Levels available Standard / Increased / Performance	●	

IoT	Standard	Optional
M-Powered		○

STANDARD SAFETY STANDARDS	
Voltage	460/3/60

OPTIONAL CONFIGURATIONS

Auxiliary Solutions Applications

- Ⓜ Mag plates
- Ⓜ Robots
- Ⓜ Hydraulic mold clamps
- Ⓜ Integrated HR controllers



Applications

- Ⓜ Milacron Technology package
 - Clamp breather sequence
 - Coining compression molding
 - Expansion/decompression molding
 - Active parallelism control
- Ⓜ Specialty Screws and Barrels
- Ⓜ Long Fiber Applications
- Ⓜ Integrated iMFLUX capabilities
- Ⓜ Stack molds
- Ⓜ E-drives
- Ⓜ Multi-Component
 - Rotary tables
- Ⓜ Oversized molds (tie rod puller)
- Ⓜ PVC/cPVC
- Ⓜ Light-weight



M-POWERED

Leading The Plastics Industry In Digital Transformation

M-Powered is a portfolio of easy-to-use observational, analytical and support services that gives customers a competitive advantage. Leveraging Industrial Internet of Things (IIoT) technology, M-Powered runs sophisticated algorithms that utilize real-time machine learning to monitor machine operations and alert before potential issues.

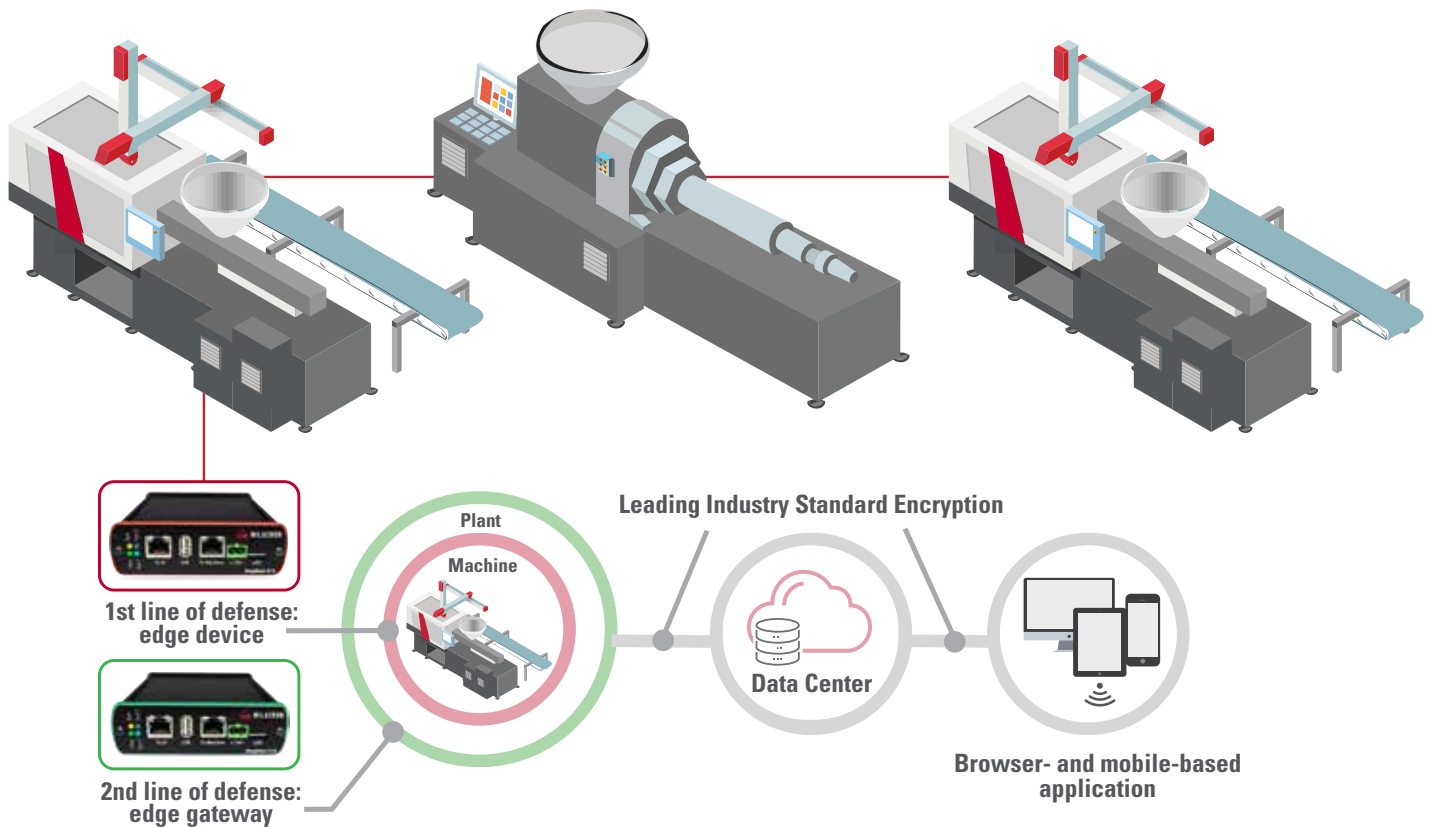

M-Powered Uses End-to-End Data Protection

M-Powered Yields Unique Intelligence On:

- 🔴 Current and Future Operations
- 🔴 Manufacturing Quality - Reduce Scrap
- 🔴 Uptime and OEE
- 🔴 Reduce Power Usage

The addition to your company's bottom line from implementing IIoT solutions are:

- 🔴 Alert for Scheduled Maintenance
- 🔴 Reduce Unplanned Outages
- 🔴 Increase Productivity

To learn more, contact SALES@MILACRON.COM or MPOWERED@MILACRON.COM.

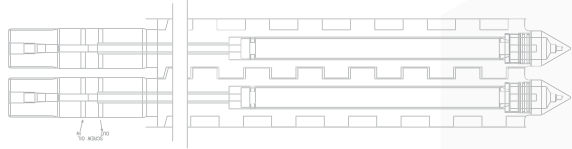
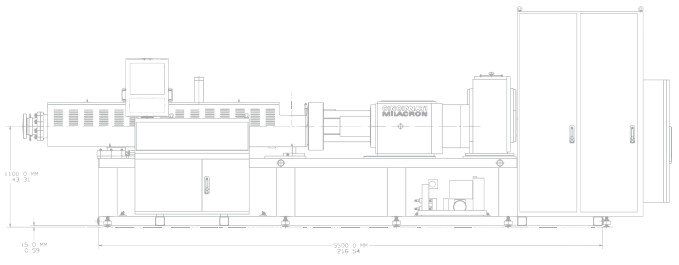
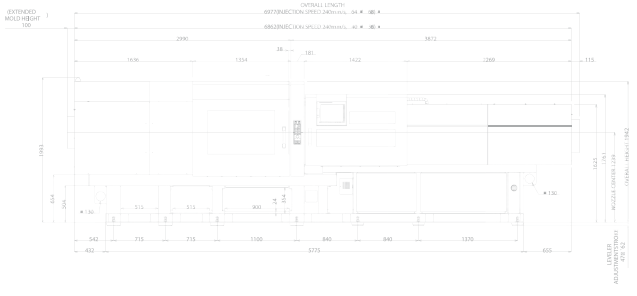
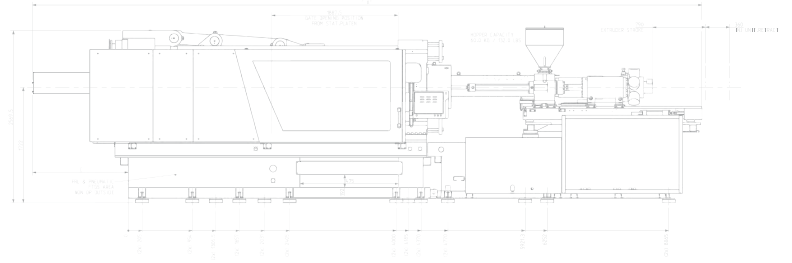

4165 Half Acre Road, Batavia OH 45103
513.536.2000
info@milacron.com | www.milacron.com

©2024 Milacron LLC. All Rights Reserved.

