



Milacron Product Information

TEMPERATURE CONTROL UNIT STACKING STAND (WATER UNITS)

When space is at a premium two temperature control units can be stacked to conserve floor space.

A stacking stand for units with up to 3 horsepower pumps and up to 16 kW heaters is offered. The stacking stand is configured from pre-engineered galvanized steel components that are bolted together to form a rigid structure. The top unit is offset so that the lower unit pressure gauges can be viewed easily.

The stand includes a single water connection from your plant cooling water source. As an option, an electrical junction box can be included for a single power supply which includes branch circuit fusing. Stacking stands can be equipped with casters as an option.

The temperature control units are shipped separately and must be mounted on the stand in the field.

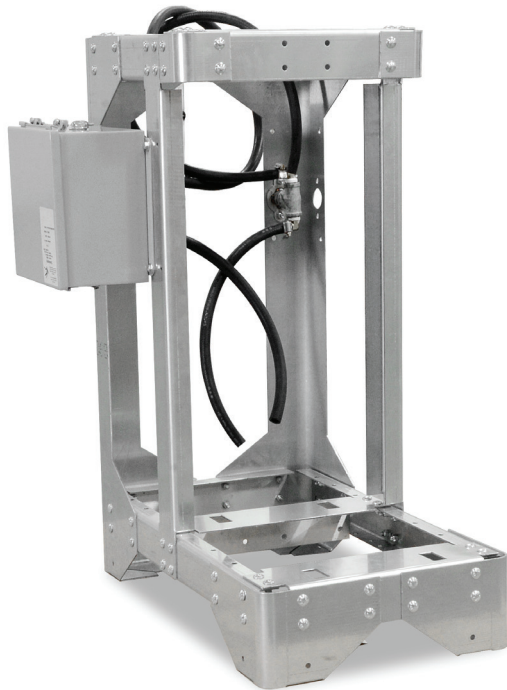

Stacking stand shown with Water Manifold and Optional Electrical Junction Box.



Stacking stand shown with Water Manifold.

Physical (on reverse)



MILACRON®

4165 Halfacre Road Batavia, Ohio 45103 www.milacron.com Phone: 513-536-2584

©2019 Milacron ADV-1006 Updated 03/11/2019

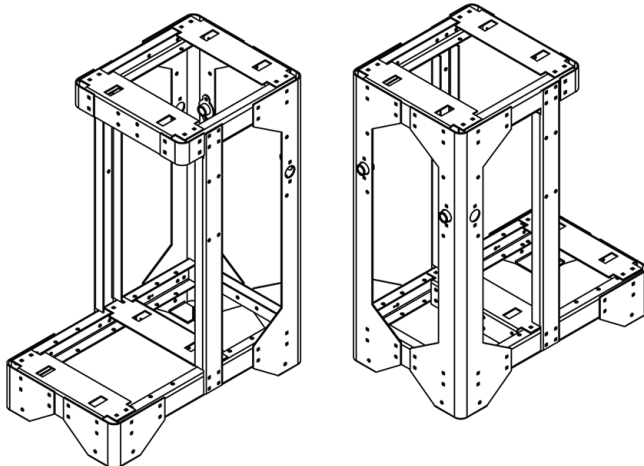
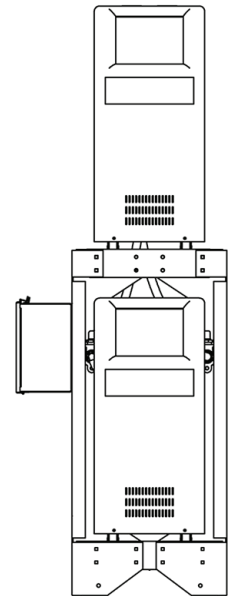
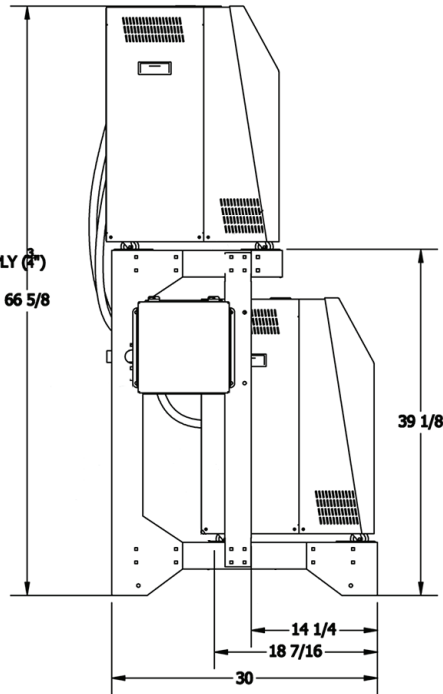
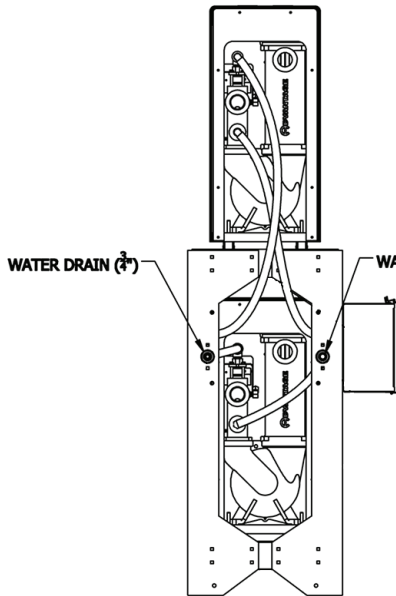
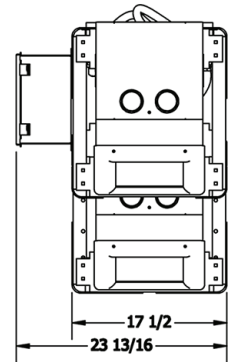
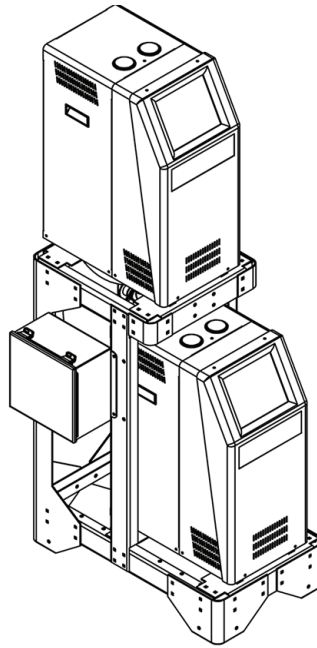

MILACRON

4165 Halfacre Road Batavia, Ohio 45103 www.milacron.com Phone: 513-536-2584

©2019 Milacron ADV-1006 Updated 03/11/2019