

# THE C-SERIES

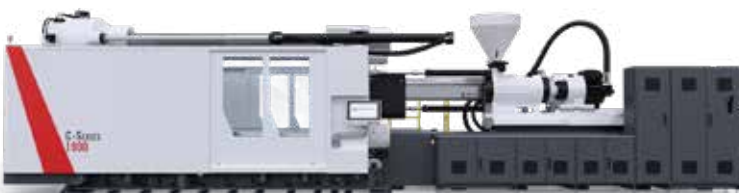

1500-6750

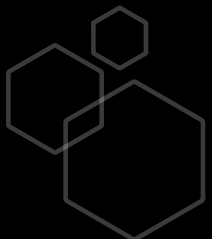

# THE C-SERIES

## 1500-6750

Introducing the next generation of Milacron innovation. The C-Series expands on Milacron's leading big machine technology through a large-tonnage two-platen press powered by an energy-efficient servo-motor hydraulic system, geared towards versatility, and designed to exceed the demands of global automotive, appliance, pallet, and other large molded

parts. Driven by the energy-efficient and highly reliable FANUC servo motor power pack, the C-Series's enhanced machine specifications and performance offer improved reliability, higher max mold weights, faster clamp speeds, and a compact footprint. The C-Series is a true global machine in design, performance, and reliability.

2



# PROVIDING THE **HIGHEST PERFORMANCE,** **POWER, AND RELIABILITY** IN A COMPACT FOOTPRINT



- Ⓜ Energy-efficient, hybrid powered by the industry-leading FANUC servo-motor
- Ⓜ Higher performance, featuring application-driven machine configuration (three standard performance packages available)
- Ⓜ Enhanced application capability: multi-component, stack tools, and larger injection unit sizes for large part production
- Ⓜ Designed for quicker mold changes, with improved mold and ejector access
- Ⓜ New Mosaic+ Control
- Ⓜ Precise platen parallelism to reduce machine, mold, and part issues
- Ⓜ Additional clamp and injection unit combinations

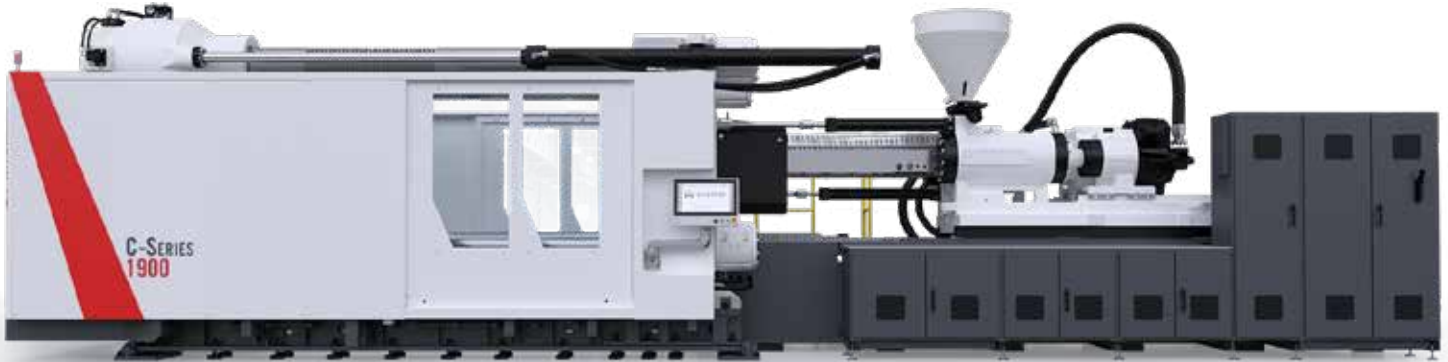

# THE C-SERIES: THE NEXT GENERATION OF MILACRON INNOVATION

### INTEGRATED LOCK NUT/TONNAGE SYSTEM

- Advanced control and improved speed
- Uniform clamp force distribution
- Supported strain rods
- Reduced mold wear
- Optional Active Parallelism Control (APC)

### COMPACT TWO-PLATEN TECHNOLOGY

- Rigid platen design deflection matching center tonnage designs
- Compact footprint
- Increased max mold weights
- Enhanced performance and reduced Euromap 6 dry cycle times

4

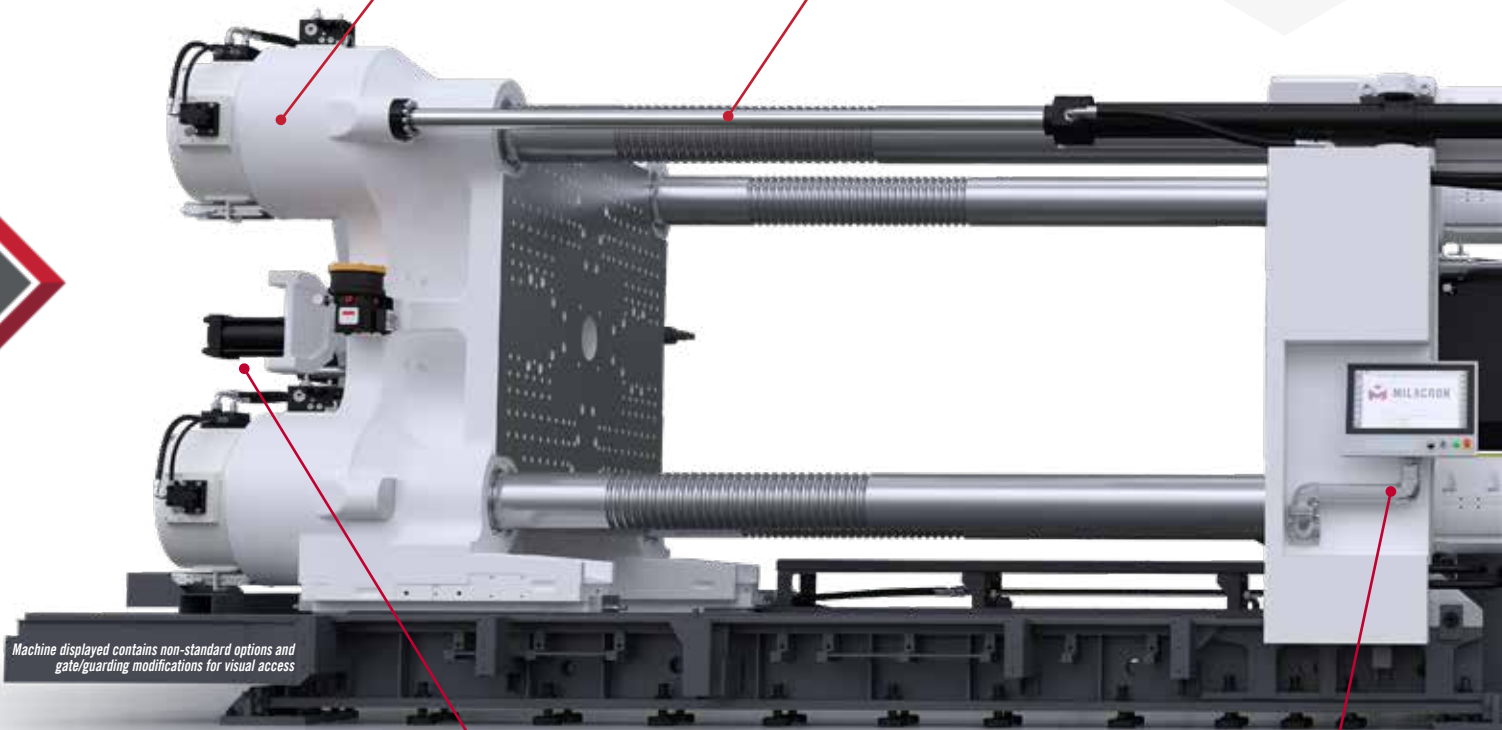

*Machine displayed contains non-standard options and gate/guarding modifications for visual access*

### STANDARD FULL SPI EJECT SYSTEM

- Full SPI ejector bar 1500-2600 tons optional on 3000 tons and larger
- Improved ejector access for reduced mold setup time

### MOSAIC+ CONTROL

- 21" multi-touch screen with configurable "PLUS" area
- Integrated auxiliary equipment screens
- Integrated remote camera interface provides an additional set of eyes monitoring the entire machine (optional)

## PROVIDING THE HIGHEST PERFORMANCE, PRECISION AND FLEXIBILITY.

## OPTIONAL INTEGRATED HOT RUNNER CONTROLLER

- Mold-Masters TempMaster iM2 Controller
- Seamless integration
- Reduced mold interface complexity
- Virtual Network Control (VNC) controlled via the Mosaic control screen
- Widest selection of interchangeable control cards

## INTEGRATED ROBOTS (OPTIONAL)

- Ultimate in mounting flexibility
- Integrated robot control through machine HMI



M-POWERED

## MILACRON M-POWERED

- Designed to fully utilize M-Powered suite of connectivity products
- Reduces failures, improves uptime and OEE

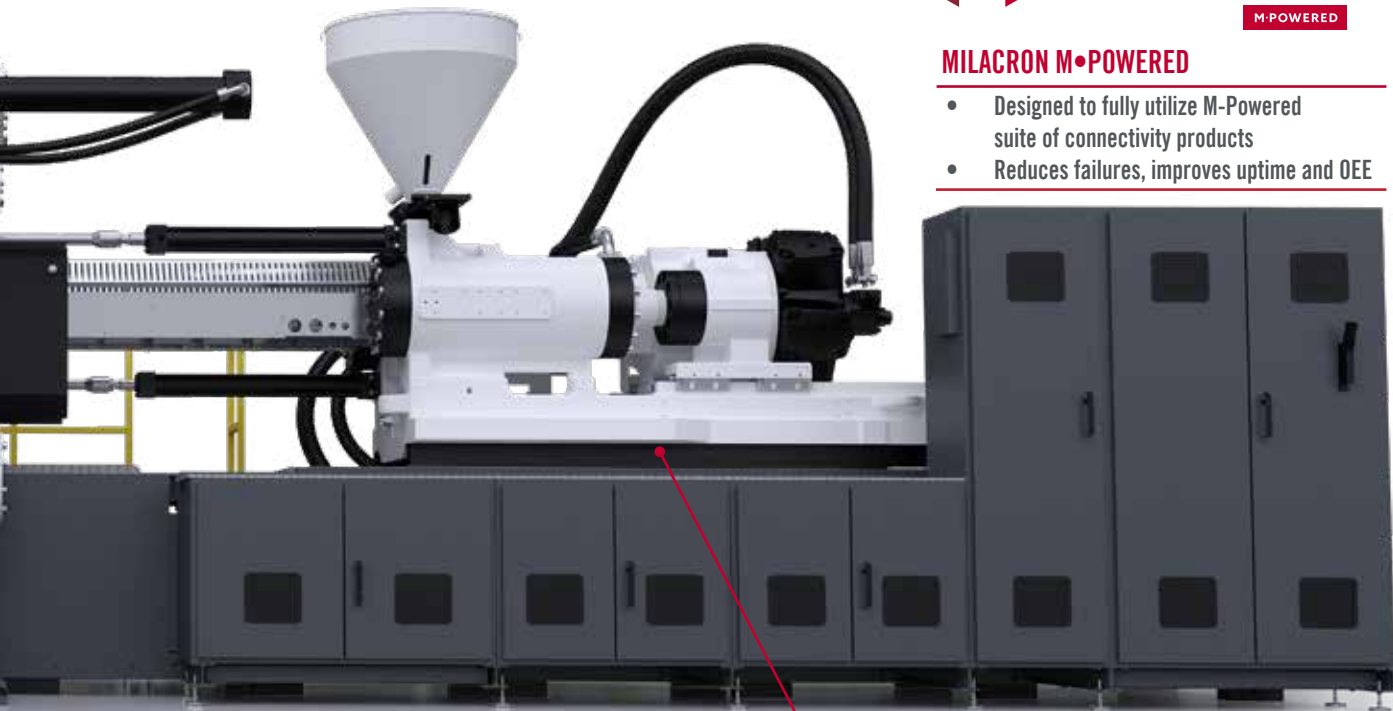

5

## FANUC MOTOR AND DRIVE PACKAGE

- Servo driven machine performance and superior reliability
- Up to 70% energy savings
- Digital control of pressure and flow via servo system
- Closed loop clamp and injection control
- Fixed gear pumps for improved reliability
- Quiet machine operation
- Offers fast acceleration rate and utilizes highly efficient and powerful permanent neodymium magnets

## MULTIPLE STANDARD INJECTION FRAMES

- A-B-C barrel combination for application flexibility
- Twin cylinder injection unit distributes the force evenly across the screw centerline
- Precision linear guides for precise screw and barrel alignment
- Standard injection unit swivel for ease of maintenance



# C-SERIES

Realize the benefits of configuring a machine that is perfectly suited to your production requirements. The C-Series has expanded options available and can be configured for a large range of parts and applications by combining the clamp and injection unit integration and screw and barrel technologies.

## INJECTION UNIT SPECIFICATIONS

Frame	6610	10100	16000	23000	34000	48000
C-SERIES 1500						
C-SERIES 1700						
C-SERIES 1900						
C-SERIES 2250						
C-SERIES 2600						
C-SERIES 3000						
C-SERIES 3600						
C-SERIES 4500						
C-SERIES 6750						

## CLAMP SPECIFICATIONS

MODEL	TONNAGE		TIE BAR SPACING	MAX DAYLIGHT	MIN / MAX MOLD
	Kilo-newton (kN)	US Tons			
C-SERIES 1500	13,000	1,470	1,650 x 1,310	2,950	700 / 1,560
C-SERIES 1700	15,000	1,690	1,750 x 1,400	2,950	700 / 1,560
C-SERIES 1900	17,000	1,920	1,850 x 1,415	3,400	700 / 1,600
C-SERIES 2250	20,000	2,250	1,870 x 1,620	3,700	700 / 1,900
C-SERIES 2600	23,000	2,590	2,020 x 1,620	3,800	800 / 1,900
C-SERIES 3000	27,000	3,030	2,175 x 1,750	3,800	800 / 2,000
C-SERIES 3600	32,000	3,600	2,270 x 1,820	4,200	900 / 2,000
C-SERIES 4500	40,000	4,500	2,325 x 2,025	4,300	900 / 2,200
C-SERIES 6750	60,000	6,745	2,900 x 2,900	5,080	1,200 / 2,500

# APPLICATIONS

The C-Series is designed to meet the changing demands of a global market. The C-Series is equipped with oversized clamp specs, increased max mold weights, and an expanded injection range to meet the demands of all the major industry market segments.

- *AUTOMOTIVE*
- *CONSTRUCTION*

- *HOUSEWARES AND APPLIANCE*
- *INDUSTRIAL APPLICATIONS*

- *STORAGE AND TRANSPORT CONTAINERS*



# COMPACT TWO-PLATEN CLAMP TECHNOLOGY

- Ⓜ Rigid platen design – deflection matching center-tonnage designs platens accommodate a large variation in mold sizes and weights
  - Small square, long vertical, long horizontal, and heavy stack tools
  - Platens designed with 'open box' construction providing:
    - Thicker platen for increased stiffness
    - Uniform force distribution across mold face
    - Low mass for increased acceleration and deceleration
- Ⓜ Enhance platen parallelism
  - Fully-supported strain rods
  - Moving platen design with integrated support bushings
  - Precision base rail guide system with adjustable platen-mounted skate blocks
- Ⓜ The C-Series delivers increased production capability in a reduced footprint using 10-20% less floor space than comparable machines.
- Ⓜ Quick mold changes through open access to ejector area, improved mold access, and large number of standard options.

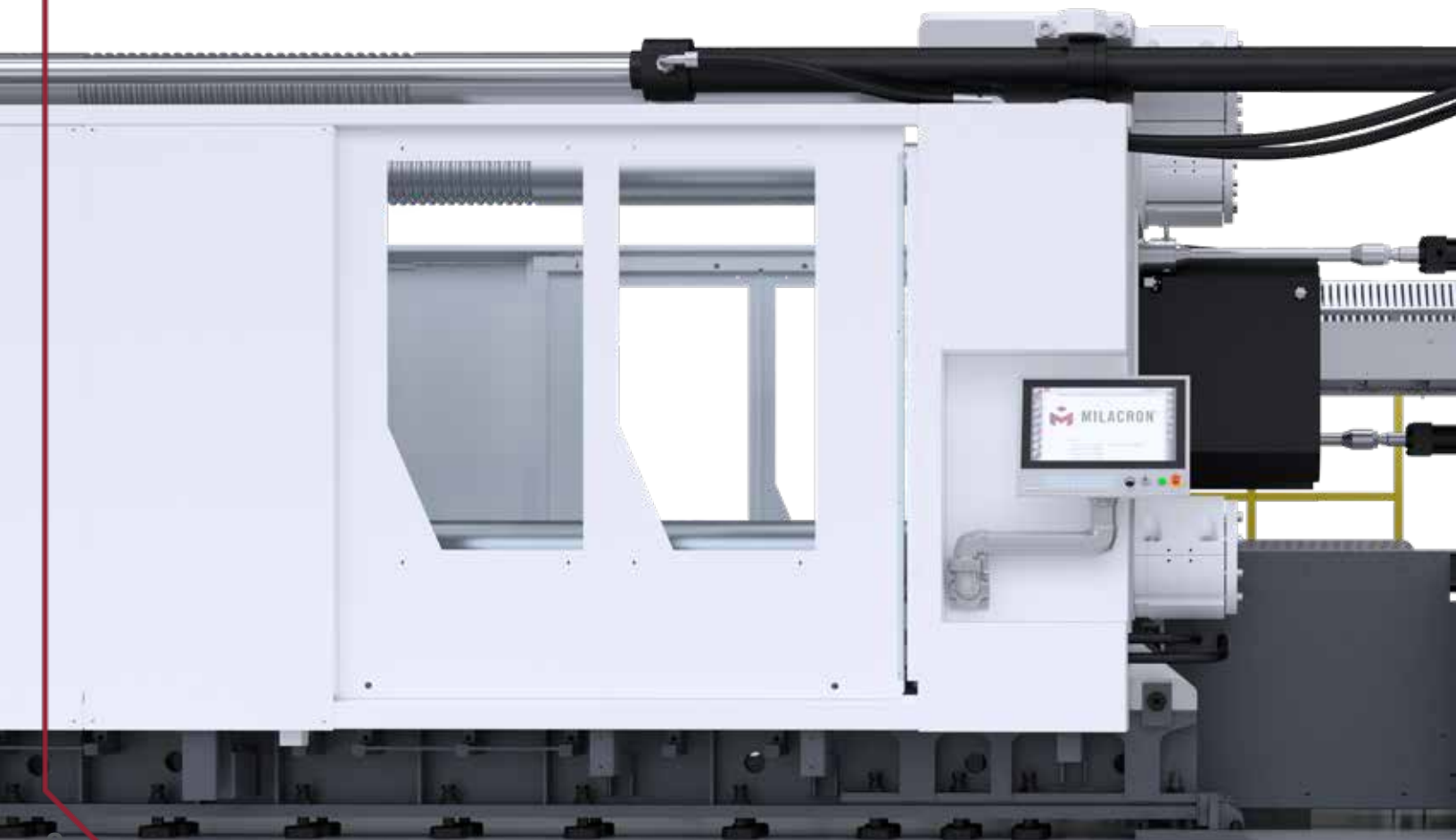



# CLAMPING UNIT

- Ⓜ Integrate lock nut and tonnage system
  - Independent control for faster lock speeds and tonnage control
  - Improved reliability and reduced cycle time
  - Higher breakaway forces
  - Improved parallelism control
  - Nut lock assembly with individual linear transducers and integrated support shoe for precise seal alignment and improved reliability
- Ⓜ High speed traverse cylinders with trunnion mount and integrated seal gland drain, allows higher clamp speed, improved alignment, and longer seal life.
- Ⓜ Optional mold access maintenance platform providing excellent access to the mold area, reducing changeover time and improving mold maintenance access. The platform provides presence sensing using adjustable springs and integrated sensors. Platform meets ANSI and CE certification requirements.
- Ⓜ Rigid and adjustable moving platen support shoes
  - The moving platen is guided and supported by large support shoes. The ridged design allows for precise side-to-side platen guidance, while providing tilt adjustment for large oversize molds.
- Ⓜ Base monitoring (optional)
- Ⓜ Automatic lubrication of the nut lock and skate components



*Tonnage Cylinder*

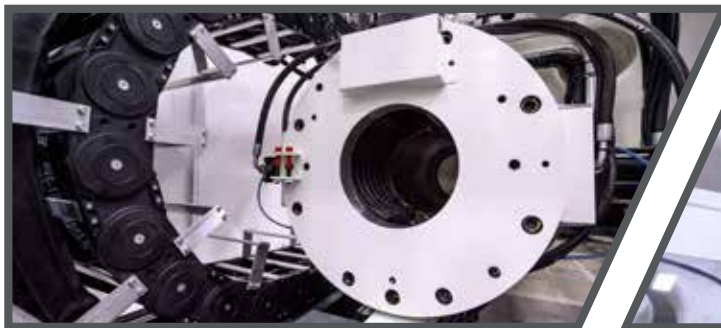

*Traverse Cylinders with Trunnion Mount*

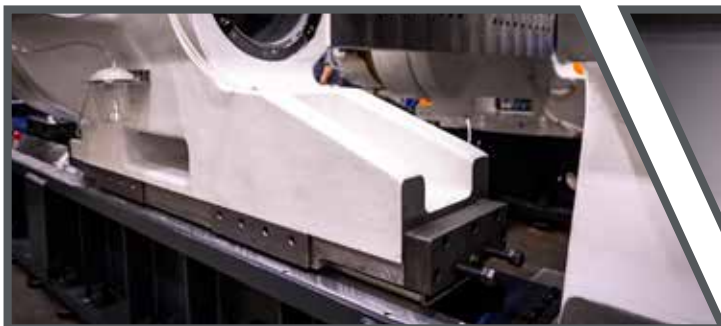

*Large Integrated Support Shoes*



*Base-Level Monitoring (Optional)*

# INJECTION UNIT

Milacron offers a wide selection of injection unit sizes, barrels, and screws for the C-Series, increasing customer flexibility in processing.

- ④ Closed-loop injection control
- ④ Higher L/D ratio – better plasticizing and homogeneity
- ④ Improved pull-pin clevis design for easy injection unit swivel
- ④ Twin-cylinder injection unit distributes the force equally across the screw centerline
- ④ Injection unit swivel for easy screw removal
- ④ 10-stage injection velocity and 10-stage injection pressure profile
- ④ 10-stage screw speed and 10-stage back pressure control (setting) through screen
- ④ Digital setting of extruder RPM and digital read out of actual RPM

10



- Ⓜ Switch over from fill-to pack based on position, time, and pressure
- Ⓜ Linear position transducer for accurate injection position control
- Ⓜ Injection decompression before/after refilling or both
- Ⓜ Semi-auto purge and cold slug removal
- Ⓜ Integrated purge platform with aluminum tread plate
- Ⓜ Insulated heater bands
- Ⓜ Barrel ID plugs
  - Automatic machine adjustment to accommodate the standard screw combinations
- Ⓜ Precision linear rail for screw alignment

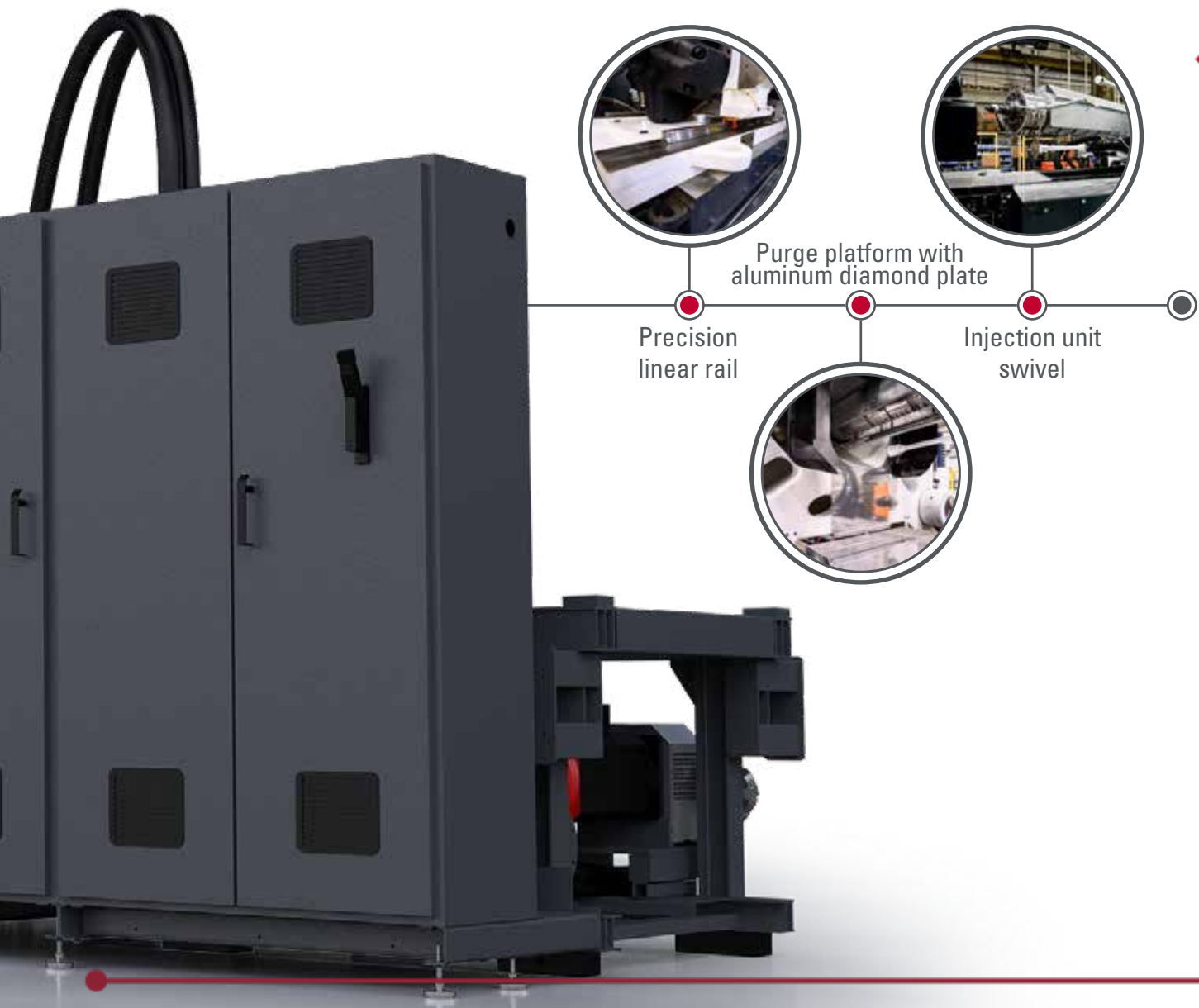

ONE MILACRON, INFINITE POSSIBILITIES

# SERVO- HYDRAULIC SYSTEM



The C-Series's enhanced machine specifications and performance are powered by proven FANUC servo-motor power packs for improved reliability, higher max mold weights, faster clamp speeds, and added tonnage sizes. Utilizing a FANUC servo-system results in a longer machine component life while also increasing oil life. The motor/pump only delivers oil as needed which reduces heat generation and water consumption.

## BENEFITS INCLUDE

- Improved cycle precision and repeatability – closed-loop system
- Reduced energy consumption
- Increased accuracy and precision – rotational control to a fraction of a degree
- High response – low inertia
- Noise reduction – up to 80% quieter than conventional hydraulic machines
- Ability to remotely monitor for troubleshooting and analysis
- Reduced sensitivity to contamination
- Increased reliability and lower maintenance costs
- Bi-directional pump for fast response in pressure control
- Pump is stopped intermittently during the cycle
- Servo-system designed for demanding and diverse applications

## FANUC HIGH-PERFORMANCE, HIGH-EFFICIENCY SERVO-MOTORS

- 50 years mean time between failures (MTBF)
- High-efficiency servo-system uses power generated during deceleration of motors, excellent energy-saving performance
- Designed to meet global safety standards (ANSI and CE)
- FANUC motors use high-energy neodymium magnets, for superior cost and performance ratios



# MOSAIC+ CONTROLLER SYSTEM

It's easy to maximize the reliability and adaptability of Milacron machines with the ergonomic touch-screen control of MOSAIC+. Fast processing speeds power extensive data collection and report generation, as well as integration with automation controls to further simplify the whole process.

## EXCEPTIONAL STANDARD FEATURES

- Multi-touch capable 21.5" HD touch screen
- Intuitive operator interface
- Configurable screen layout
- Remote mounted IP camera interface
- Windows based operating system
- Optional integrated Mold-Masters hot runner control



*MOSAIC+ Screen versatility gives the operator simultaneous views of multiple machine functions and related equipment, such as hot runner control and remote mounted IP cameras.*

- Set point overview page for quick access – actual set points for each axis at the bottom of the page
- Display of 700 process monitor samples stored on control or virtually unlimited samples on USB stick or network drive via reports
- Graphic display of 33 integrated soft keys with LED's located below screen
- Process monitoring of over 50 possible parameters with graphically displayed min, max, and average
- 8 + 8 freely configurable I/O
- Self diagnostic and fault finding capability
- 8 SPC distribution, XBar, and R charts with over 50 possible parameters
- Data protection with 4 access levels for up to 30 machine operators
- Fully-configurable cores
- Save mold data and screen shots to USB keys
- Change log and alarm log are 700 on the control, virtually unlimited on USB stick or network drive via reports

# PLUS SCREEN TECHNOLOGY

The PLUS section has four configurable window spaces. In this section, the operator can choose to show:

- 🔴 Four small windows
- 🔴 One large and two small windows
- 🔴 Two large windows

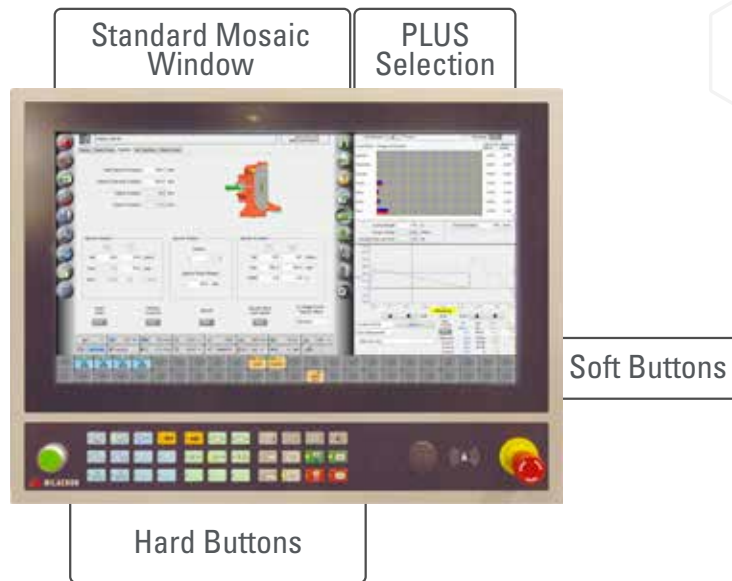

Content choices for the four windows include:

- 🔴 Alarms log
- 🔴 Energy overview
- 🔴 Production run
- 🔴 Injection graphics
- 🔴 Trend data analysis
- 🔴 Trend graphics
- 🔴 Cycle analysis
- 🔴 SPC charts
- 🔴 Integrated robot, dryer and hot runner (optional)
- 🔴 Status page
- 🔴 Integrated camera with zoom capability (optional)



# HIGH-QUALITY COMPONENTS



1. Motor/Drives - FANUC

2. Control Hardware - B&R



3. High Speed Traverse Cylinders - Douce Hydro/ ATOS

4. Control Valves - RexRoth/ ATOS



5. Fixed Gear Pump - Voith

6. Filtration - Hydac



7. Auto Lubricator - Dropsa

8. Extruder Motor - Calzoni



# STANDARD FEATURES

	Standard	Optional
<b>GENERAL</b>		
Advanced 2 Platen Technology powered by energy efficient servo motor hydraulic system	●	
Power pack driven by proven FANUC AC servo motor and drive package	●	
Direct control of pressure and flow via internal gear pumps	●	
Multiple servo motor system for parallel operation of eject and core pull	●	
Improved layout of manifolds and hoses on non-operator side	●	
Monitored shut off valve to pump suction lines	●	
Pressure transducer for reduced down time with LED lighted dual channel	●	
Designed for serviceability (test ports, access, etc)	●	
Independent full time kidney-loop filtration and cooling	●	
External filtration system		○
Filtration to 3 micron with clog detection and alarm	●	
Ports for external auxiliary filtration plumbing	●	
High base designs for part removal		○
Open access to ejector area for quick/easy mold change	●	
Eject area safety interlocked access door	●	
Robot interface ANSI146 (compatible with Euro-map 67)	●	
SPI robot mounting pattern on stationary platen standard for C1500 and C1700 US ton models	●	
Robot mounting pads on stationary platen standard for C1900 and larger	●	
Plates required for SPI pattern		○
Power operated operator's gate	●	
Flareless bite type fittings with elastomeric seals for hydraulic tubes connections	●	
Injection purge platform	●	
Operator and non-operator access		○
Steps into operator gate enclosure (2250 ton and larger)	●	
Improved mold area access	●	
Optional die area platform		○
Ventilated control cabinet mounted outside of base with over temperature alarm	●	
Electrical Cabinet Air Conditioner		○
Anchor blocks mounted to machine base (Customer supplied anchor bolts and installation) Leveling pads	●	
Y strainer in heat exchanger inlet for all machines	●	
Water manifold with single IN/OUT connection for cooling water requirements of heat exchanger and feed throat	●	
Non operator side cycle interrupt button	●	
	Standard	Optional
<b>CLAMP</b>		
2 Platen Clamp design with fixed strain rod position and tonnage pads on moving platen	●	
Integrate twin cylinder high speed nut lock system	●	
Compact footprint	●	
Increased max mold weight capacity	●	
Reduced (Euro-map 6) dry cycle times	●	
Catrac cable carrier for reduce hose wear	●	
Closed loop mold protection	●	
Position based ramping of the Moving Platen	●	
"Mold Guard" Enhanced full stroke mold protection	●	
SPI mold mounting pattern on platens	●	
Extended and adjustable moving platen support shoes riding on hardened steel ways	●	
Replaceable 5" diameter die locating ring on stationary platen	●	
Pre-clamp open sequence	●	
Generously tapered conical hole in stationary platen	●	

	Standard	Optional
<b>CLAMP (CONTINUED)</b>		
Traverse cylinders for fast traversing speeds and mold breakaway force	●	
Increased breakaway force using main cylinder area	●	
Automatic lubrication of strain rods, skates and lock nuts	●	
Self adjusting ratchet style jam bar		○
	Standard	Optional
<b>INJECTION</b>		
Twin cylinder injection units for compact footprint	●	
Diagonal mounted twin pull-in cylinders for even nozzle force distribution (10100 and larger)	●	
Closed loop injection pressure and velocity control (thru pump)	●	
Closed loop back pressure control through proportional valve	●	
Closed loop feed throat temperature monitor and control, alarm only	●	
Injection fill to pack by screw position, volume, pressure, or time	●	
Direct drive single stage hydraulic screw motor	●	
Ball check or short stroke slider ring	●	
Nitrided barrel and general purpose medium compression screw (10100 and larger)	●	
Nitrided barrel and general purpose barrier screw (6610 frames and smaller)	●	
Nozzle contact force by pressure switch	●	
Sprue break by timer	●	
Solid State relays for barrel heats	●	
Injection unit swivel for easy nozzle, screw, and barrel maintenance (power swivel 10100 and larger)	●	
J-Style Thermocouples	●	
Hopper slide with shutoff, open/close, op side emptying (Optional powered slide)	●	
Heater zones labeled per Euromap 5	●	
Insulated heater bands	●	
6 Zones barrel heats (6610-23000) and 7 Zone (34000 & Larger)	●	
Barrel ID plugs / control pre-configured for (A, A, B) barrel combinations	●	
Enhanced injection rate up to 10% through regenerative injection fill (reduced max pressure)	●	
Nozzle endcap and nozzle body with inch threads	●	
Nozzle tip with 1/2" radius and .12" orifice 6610 and larger	●	
	Standard	Optional
<b>EJECT</b>		
Standard machine mounted eject system (SPI) (C1500, C1700, C1900, C2250, and C2600 )	●	
Credit for removed ejector system option available on above models		○
Standard mold mounted eject system - machine mounted KO bar and cylinder not included (C3000, C3600, and C4500 )	●	
Machine mounted eject system (SPI) (C3000, C3600, C4500)		○
Pilot operated check valve for machine eject system	●	
Pulsating ejection	●	
Position transducer used for setup and readout of ejector positions	●	
Proportional control of eject speed and pressure (operator adjustable at control)	●	
Two forward eject speed set points	●	
Eject forward dwell timer	●	
Eject retract override	●	
Intermediate eject retract set point	●	
Eject on fly/independent eject	●	
Eject retract limit switch verification (software/signals only)	●	
	Standard	Optional
<b>MACHINE POWER PACK</b>		
3 Performance Levels available (Standard, Increased, and Performance) Performance levels affect injection, extruder, clamp, eject, and core specifications See machine specification sheet for details	●	

# WORKCELL INTEGRATION & APPLICATIONS

## AUXILIARY SOLUTIONS

- Hot runner controllers
- Integrated robot cells
- Dryers
- Hydraulic mold clamping systems
- Conveyors
- Portable chillers and mold temp controllers



## APPLICATIONS

- Milacron technology package
  - Clamp breather sequence
  - Coining compression molding
  - Expansion/decompression molding
  - Active parallelism control
- Specialty screws and barrels
- Long fiber applications
- Mono-sandwich/co-injection
- Integrated iMFLUX technology
- Stack molds
- Electric screw drive
- Multi-component
- Tie rod puller
- PVC/cPVC solutions
- Lightweighting



*Tie rod puller*



*Perpendicular 2<sup>nd</sup> injection unit*



# M·POWERED

## Leading The Plastics Industry In Digital Transformation

M-Powered is a portfolio of easy-to-use observational, analytical and support services that gives customers a competitive advantage. Leveraging Industrial Internet of Things (IIoT) technology, M-Powered runs sophisticated algorithms that utilize real-time machine learning to monitor machine operations and alert before potential issues.

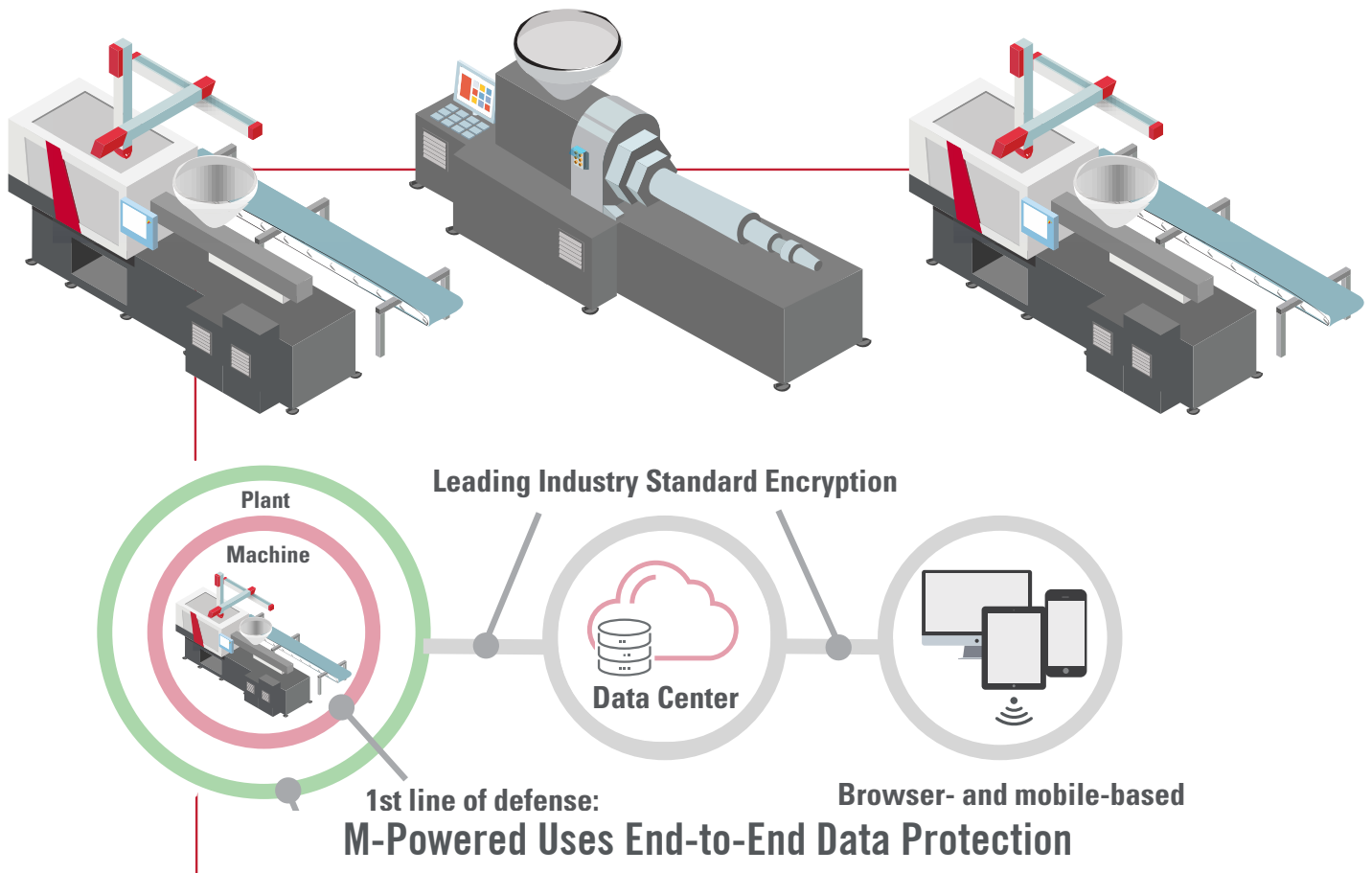

### M-Powered Yields Unique Intelligence On:

- Current and Future Operations
- Manufacturing Quality - Reduce Scrap
- Uptime and OEE
- Reduce Power Usage

The addition to your company's bottom line from implementing IIoT solutions are:

- Alert for Scheduled Maintenance
- Reduce Unplanned Outages
- Increase Productivity

To learn more, contact [SALES@MILACRON.COM](mailto:SALES@MILACRON.COM) or [MPOWERED@MILACRON.COM](mailto:MPOWERED@MILACRON.COM).

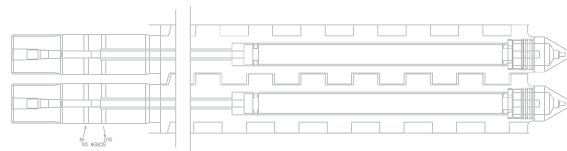
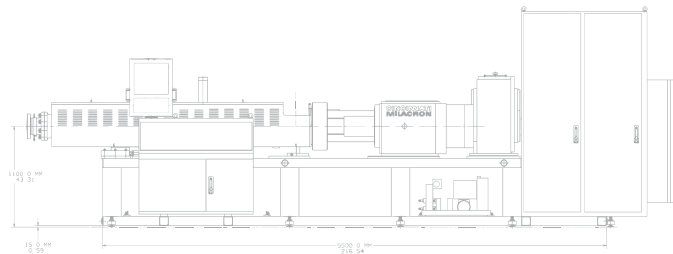
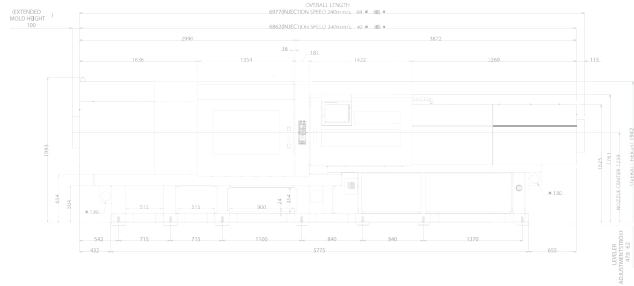
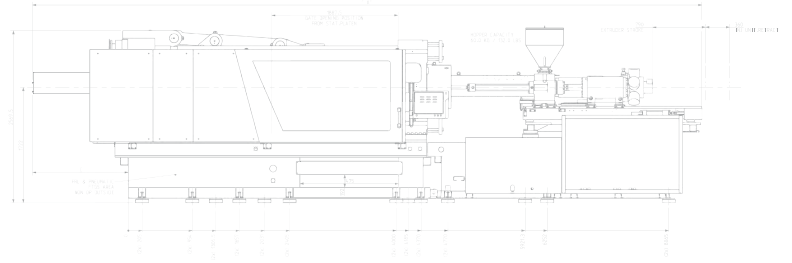

4165 Half Acre Rd., Batavia OH 45103  
 513.536.2000  
 info@milacron.com | www.milacron.com

©2023 Milacron LLC. All Rights Reserved.

